

STANDARD FEATURES

- **AVAILABLE WATTAGE:** 125 – 500W
- **SIZE:** 122 x 60 x 34mm
- **AVERAGE WEIGHT:** 105g
- **RESISTANCE WIRE MATERIAL:** Iron-chrome aluminium
- **HEATER VOLTAGE:** 230V standard
- **USEFUL WAVELENGTH RANGE:** 2-10 microns
- **AVERAGE OPERATING LIFE:** 20,000 hrs
- **RECOMMENDED RADIATION DISTANCE FROM HEATER:** 100-200 mm
- **MIN RECOMMENDED SPACING BETWEEN ELEMENTS:** 5mm
- **OTHER VARIATIONS:** voltages, wattages, lead length and terminations available on request

GENERAL INFORMATION

- **EFFICIENT HEATING:** Ceramic infrared heaters are highly efficient because they directly heat objects and surfaces rather than the air. This targeted heating reduces energy waste and provides effective warmth exactly where it is needed.
- **RAPID HEAT-UP TIME:** These heaters can reach their operating temperature quickly and start emitting heat almost immediately. This is beneficial in industrial settings where rapid heating is required to maintain process temperatures or ensure worker comfort.
- **ENERGY SAVINGS:** By focusing heat directly on surfaces and materials, ceramic infrared heaters reduce the amount of energy needed to achieve the desired temperature.
- **UNIFORM HEAT DISTRIBUTION:** Our ceramic infrared heaters provide even heat distribution, minimizing temperature fluctuations within the heated area. This uniformity is crucial in industrial processes that require consistent temperatures for quality control and operational efficiency.
- **REDUCED AIR MOVEMENT:** Since these heaters do not rely on heating air, they minimize air movement and dust circulation. This can be particularly advantageous in environments where clean air is critical, such as in manufacturing processes involving sensitive materials.
- **LOW MAINTENANCE:** Our ceramic infrared heaters have durable ceramic elements that require minimal maintenance. They do not have moving parts, reducing the likelihood of mechanical failure and the need for frequent repairs.
- **LOCALIZED HEATING:** They allow for localized heating, specific areas or workstations can be heated independently of the rest of the facility which is useful for processes or tasks that require precise temperature control.
- **DURABILITY:** The robust construction of ceramic infrared heaters makes them suitable for harsh industrial environments. They are designed to withstand high temperatures and challenging conditions.
- **ECO-FRIENDLY:** These heaters operate more efficiently than conventional heating methods, potentially leading to reduced carbon footprints and more sustainable operations.

TECHNICAL INFORMATION

Available Wattage	150	250	300	400	500	650	750	800	1000
Mean surface temp (°C)	272	351	405	480	515	596	624	639	726
Max power density (kW/m ²)	9.2	15.3	18.4	24.6	30.7	40	46.1	49.2	61.5

DRAWINGS

HTE

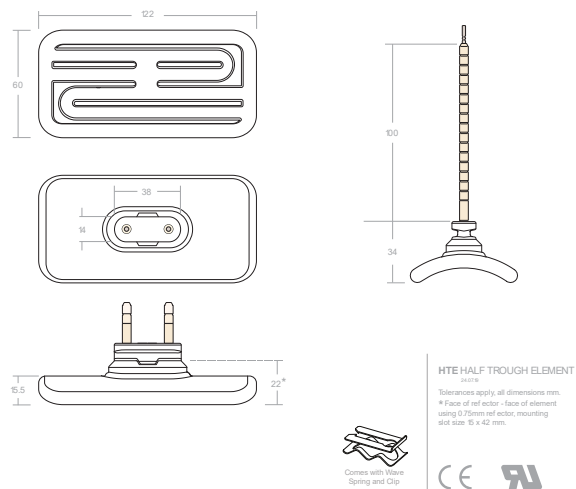

HTE + TC

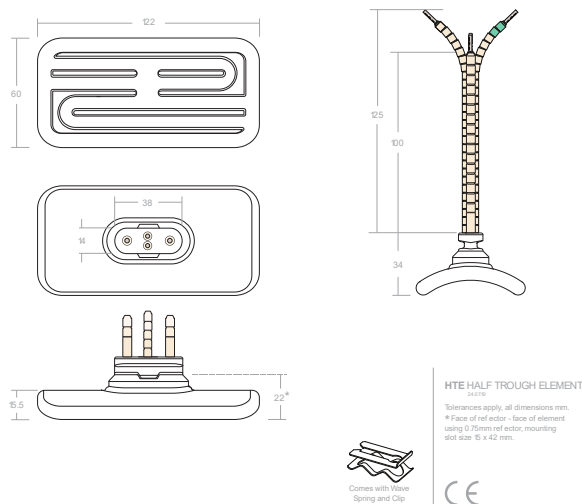

Wave and Spring Clip

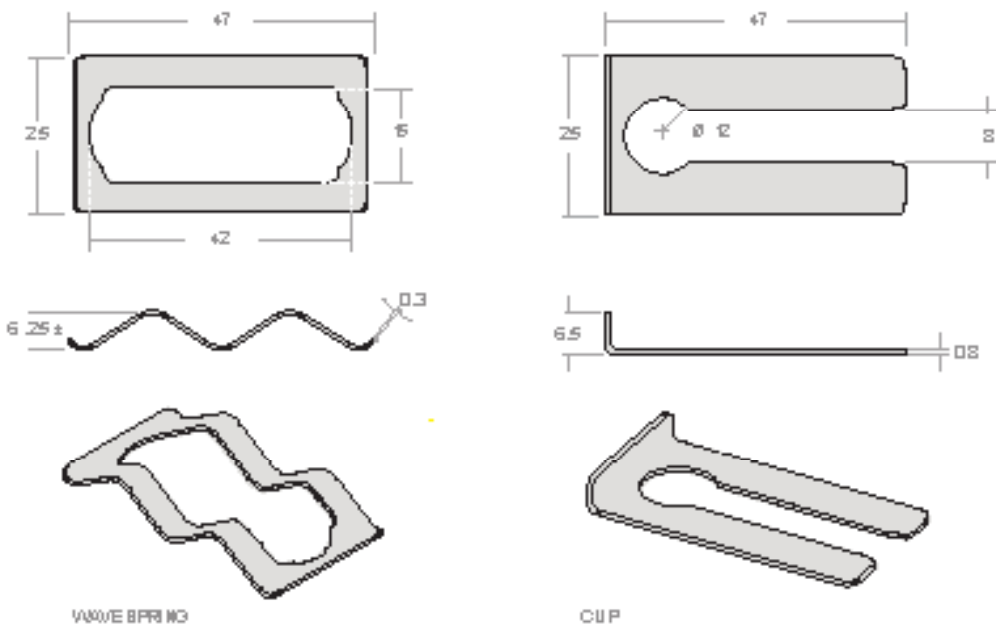

WAVE SPRING AND CLIP
 Tolerances apply, all dimensions mm.
 CE