

CUSTOM FLEX RISER PTFE HEATERS

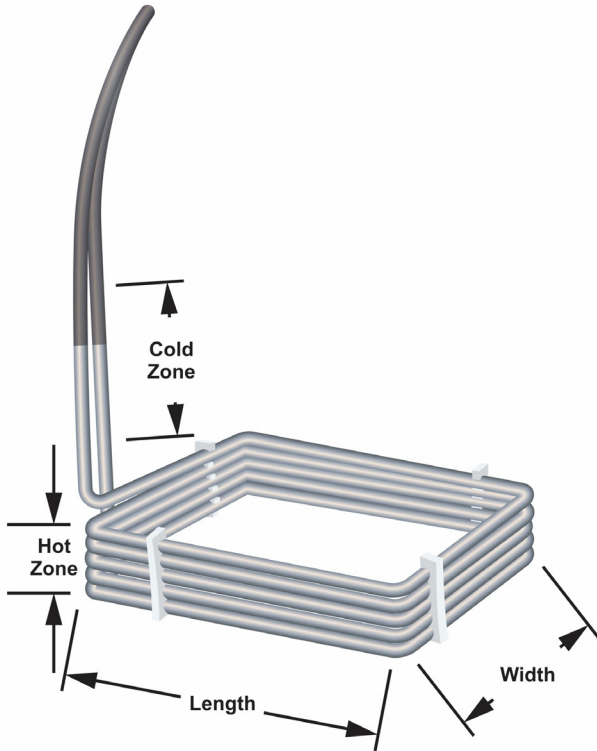

INFORMATION

- Fluoropolymer (PTFE) heaters are an excellent choice for heating Aqueous acid, alkaline, anodizing and pickling solutions up to 212F (100 C).
- Offers thick gauge stainless steel tubular elements covered with heavy wall fluoropolymer (PTFE) reducing permeation, eliminating the need for gas purge systems. This product is an excellent choice for heating electroless chemistries – not for use in Chromic Acid.

FEAUTRES

Custom Flexible Riser Single Phase Heater. Excellent chemical resistance to aggressive acids.

- PTFE sleeved 304 stainless elements inert to most solutions up to 212°F (100°C).
- Low watt density design 10 watts/square inch (1.5w/cm²).
- 4 foot (1.2m) continuous fluoropolymer (PTFE) cable leading to a vapor resistant terminal enclosure and 3 ft (.9m) flexible Teflon liquid tight conduit.
- Grounded internal metal element and built in thermal protector. Resettable P3 protector standard



PROTECTOR / FUSE OPTIONS

	CODE	TYPE OF FUSE	DESCRIPTION
FLEX RISER	P3	RESETTABLE	For solutions up to 250°F (121°C)
RIGID RISER	P1	REPLACEABLE	Standard for solutions up to 180°F (82°C)
	P4	REPLACEABLE	For solutions up to 230°F (110°C)
	P2	RESETTABLE	For solutions up to 190°F (88°C)
	P8	RESETTABLE	For solutions from 190°F to 210°F (88°C to 99°C)
	P3	RESETTABLE	For solutions from 210°F to 250°F (99°C to 121°C)

STANDARD PARTS

MPI P/N	WATTS	VOLTS	Width	LENGTH	PHASE
IM-HXSL11**_**_**	1000 W	120 V	N/A	N/A	Single
IM-HXSL12**_**_**	1000 W	240 V	N/A	N/A	Single
IM-HXSL21**_**_**	2000 W	120 V	N/A	N/A	Single
IM-HXSL22**_**_**	2000 W	240 V	N/A	N/A	Single
IM-HXSL24**_**_**	2000 W	480 V	N/A	N/A	Single
IM-HXSL32**_**_**	3000 W	240 V	N/A	N/A	Single
IM-HXSL34**_**_**	3000 W	480 V	N/A	N/A	Single
IM-HXSL42**_**_**	4000 W	240 V	N/A	N/A	Single
IM-HXSL44**_**_**	4000 W	480 V	N/A	N/A	Single
IM-HXSL52**_**_**	5000 W	240 V	N/A	N/A	Single
IM-HXSL54**_**_**	5000 W	480 V	N/A	N/A	Single
IM-HXSL62**_**_**	6000 W	240 V	N/A	N/A	Single
IM-HXSL64**_**_**	6000 W	480 V	N/A	N/A	Single

Single phase only, **_** Specify Width & Length, **Specify Protector / Fuse

3-4 Week Lead Time for Standard & Custom Products!

ORDER CODE

IM-HXSL XX X XX - XX X - XXXX - XX									
SERIES	WATTAGE	VOLTAGE	WIDTH	LENGTH	RISER LOCATION	RISER OPTION	TYPE OF PROTECTOR		
HXSL - 3 element PTFE sheathed	1	1000W	1	120V	Specify in inches	L = Left front corner	FR = Flex riser length , specify length in inches	THERMAL PROTECTOR (Flex Riser) RESETTABLE FUSE	
	2	2000W	2	240V				R = Right front corner	Ex: FR48 = 48"
	3	3000W	3	380V	R = Rigid riser length REPLACEABLE FUSE	P1(std)- SOLUTIONS UP TO 190°F			
	4	4000W	4	480V		P4- SOLUTIONS UP TO 220°F RESETTABLE FUSE			
	5	5000W	5	415V		P2- SOLUTIONS UP TO 190°F			
	6	6000W	6	600V			P8- 190°F TO 210°F		
			7	400V			P3- 210°F TO 250°F		
			8	208V					
			9	220V					
		0	200V						
WIRE & CONDUIT LENGTH blank - 36" TEFLON CONDUIT	EX. IM-HXSL328-9L-FR48-P3 CUSTOM FLEX RISER PTFE Immersion Heater, 3kW, 240V, 8" Width, 9" Length. Left Front Corner Riser, 48" Flex Riser Length, P3 Resettable Fuse for Solutions up to 250degF, 36" Teflon Conduit								
SPECIFY LENGTH - EX. X84 = 84" TEFLON CONDUIT									