

## A400 - MELT BOLT T/C and RTD'S

### DESCRIPTION

A400 Series Melt Bolt Thermocouples and RTD's are ideal to measure polymer temperature inside the extrusion or injection molding machine. The tip can stick as much as 1" (25mm) into the plastic flow. The temperature sensors are designed to fit in the exact same hole as our melt pressure transducers / Transmitters.

### A400 - FIXED TIP STYLE

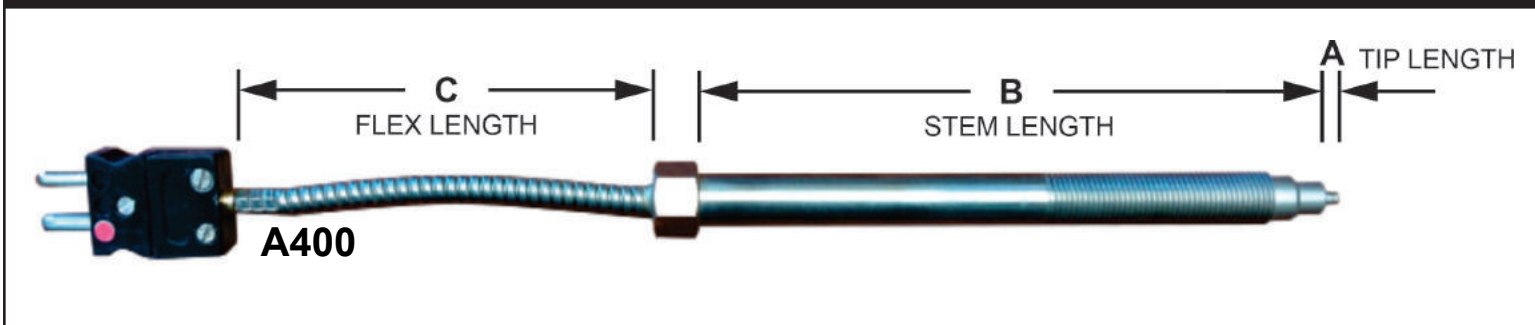

### STANDARD FEATURES

Max Pressure : 20,000psi (1400bar)  
 Max Temp : 900°F (450°C)  
 Body : 304 S/S  
 Tip Length : Flush to 1" (0-25mm)  
 Threads : 1/2-20UNF, M14X1.5, M18x1.5  
 Sensor : Thermocouple J/K, PT100 RTD  
 Bolt Length : 2" - 12" (50-305mm)

**Fits Standard Melt Pressure Transducer Hole**

### LEAD MATERIAL



**F - FIBERGLASS**  
 MAX TEMP: 900°F(485°C) MOISTURE: GOOD CHEMICAL: GOOD ABRASION: FAIR



**B - STAINLESS BRAID**  
 MAX TEMP: 900°F(485°C) MOISTURE: GOOD CHEMICAL: GOOD ABRASION: EXCELLENT



**H - STAINLESS HOSE**  
 MAX TEMP: 900°F(485°C) MOISTURE: EXCELLENT CHEMICAL: EXCELLENT ABRASION: EXCELLENT



**T - TEFLON**  
 MAX TEMP: 500°F(260°C) MOISTURE: EXCELLENT CHEMICAL: EXCELLENT ABRASION: GOOD



**S - FIBERGLASS STRANDED**  
 MAX TEMP: 900°F(485°C) MOISTURE: GOOD CHEMICAL: GOOD ABRASION: FAIR

### A40 - ORDER CODE

A40X		X	-	A	-	B	-	C	-	X	-	X	-	X
TIP DIAMETER	TYPE	TIP LENGTH		STEM LENGTH		LEAD LENGTH		TERMINATION		LEADS		OPTIONS		
0 - 1/8"D TIP	J - TYPE J	0 - FLUSH		3 - 3" (76mm)		0		0 - STRIPPED LEADS		F - FIBERGLASS STRANDED		U - UNGROUNDED		
3 - 3/16"D TIP	K - TYPE K	1/8 - 1/8" (3.2mm)		4 - 4" (101mm)		6 - 6" (152mm)		1 - FORK TERMINALS		B - STAINLESS BRAID		N - 1/2"-20UNF GROUNDED		
	T - TYPE T	3/16 - 3/16" (4.7mm)		6 - 6" (152mm)		24 - 24" (610mm)		2 - STANDARD MALE PLUG		H - STAINLESS HOSE		M18 - M18x1.5 THREAD		
	RTD2 - PT100	1/4 - 1/4" (6.3mm)		8 - 8" (203mm)		48 - 48" (1220mm)		3 - STANDARD FEMALE JACK		T - TEFLON		M14 - M14x1.5 THREAD		
	RTD3 - PT100	X - CUSTOM		X - CUSTOM		120 - 120" (1220mm)		4 - MINI MALE PLUG		S - FIBERGLASS SOLID				
						X - CUSTOM		5 - MINI FEMALE JACK						

**\*\*Standard Lead Time for Custom Parts 3-5 days MFG\*\***  
**If you need something that is not listed, contact us! We can probably make it**

## A40A - MELT BOLT T/C and RTD'S - ADJUSTABLE STYLE

### A40A - ADJUSTABLE STYLE

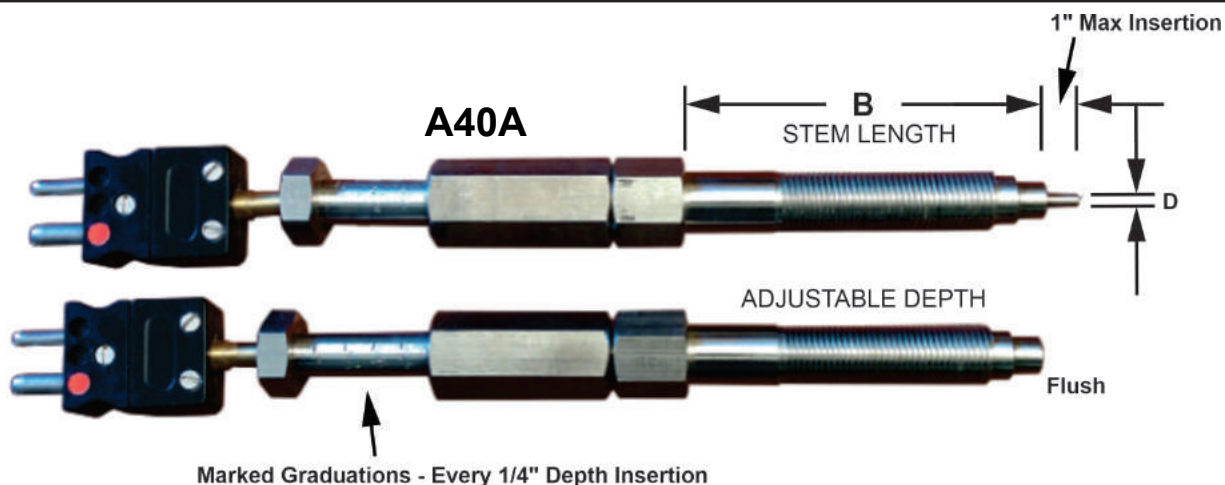

### STANDARD FEATURES

Max Pressure : 10,000psi (700bar)  
 Max Temp : 500°F (260°C)  
 Body : 304 S/S  
 Tip Length : Flush to 1" (0-25mm)  
 (Adjustable under Pressure)

**Fits Standard Melt Pressure Transducer**

### THREAD DIMENSIONS

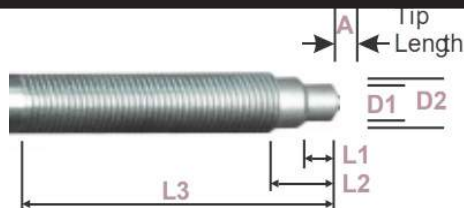

Dim.	1/2"-20UNF	M14x1.5	M18x1.5
D1	0.306" (7.8mm)	0.315" (8.0mm)	0.394" (10.0mm)
D2	0.413" (10.5mm)	0.472" (12.0mm)	0.630" (16.0mm)
L1	0.209" (5.3mm)	0.236" (6.0mm)	0.236" (6.0mm)
L2	0.433" (11.0mm)	0.472" (12.0mm)	0.551" (14.0mm)
L3	1.063" (27.0mm)	1.260" (32.0mm)	1.338" (34.0mm)

### A40A - ORDER CODE

<b>A40AX</b>	<b>X</b>	<b>-</b>	<b>B</b>	<b>-</b>	<b>X</b>	<b>-</b>	<b>X</b>
<b>TIP DIAMETER</b>	<b>TYPE</b>	<b>STEM LENGTH</b>	<b>TERMINATION</b>	<b>OPTIONS</b>			
- 1/8"D TIP	J - TYPE J	3 - 3" (76mm)	0 - STRIPPED LEADS	U - UNGROUNDED			
3 - 3/16"D TIP	K - TYPE K	4 - 4" (101mm)	1 - FORK TERMINALS	N - 1/2"-20UNF GROUNDED			
	T - TYPE T	6 - 6" (152mm)	2 - STANDARD MALE PLUG	M18 - M18x1.5 THREAD			
	RTD2 - PT100	8 - 8" (203mm)	3 - STANDARD FEMALE JACK	M14 - M14x1.5 THREAD			
	RTD3 - PT100	X - CUSTOM	4 - MINI MALE PLUG				
			5 - MINI FEMALE JACK				

### TERMINATIONS

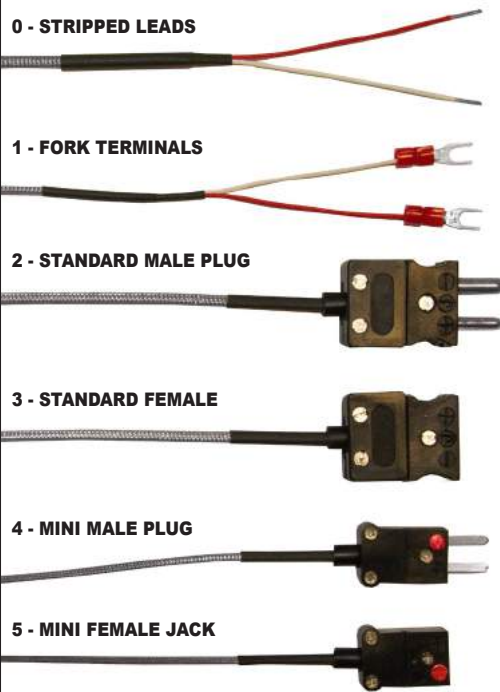

**\*\*Standard Lead Time for Custom Parts 3-5 days MFG\*\***  
**If you need something that is not listed, contact us! We can probably make it**

## A40B - MELT BOLT T/C and RTD'S - BLADE STYLE

### A40B - BLADE STYLE

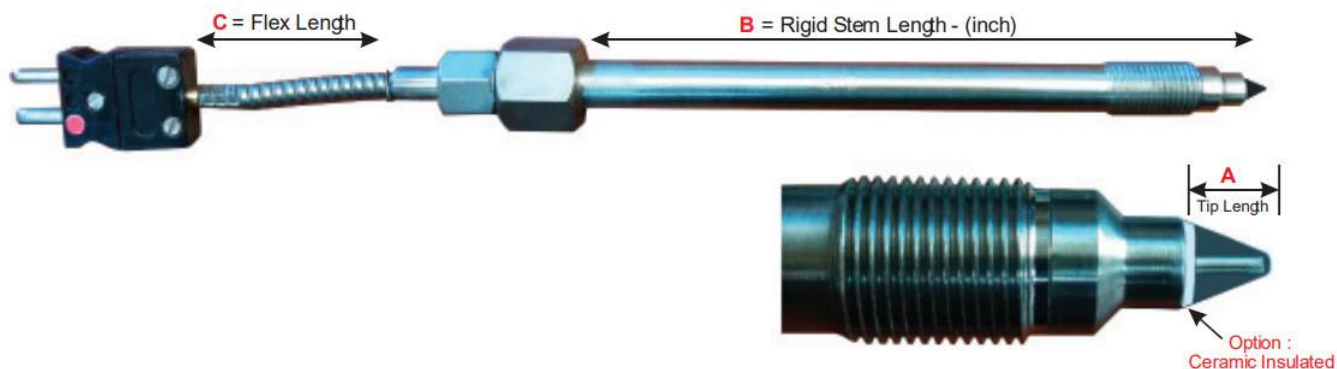

#### STANDARD FEATURES

- Max Pressure : 15,000psi (1000bar)
- Max Temp : 900°F (450°C)
- Body : 304 S/S
- Tip Length : Flush to 1" (0-25mm)
- Blade : Can be adjusted to flow direction

**Fits Standard Melt Pressure Transducer Hole**

#### LEAD MATERIAL

**F - FIBERGLASS**  
 MAX TEMP: 900°F(485°C) MOISTURE: GOOD CHEMICAL: GOOD ABRASION: FAIR

**B - STAINLESS BRAID**  
 MAX TEMP: 900°F(485°C) MOISTURE: GOOD CHEMICAL: GOOD ABRASION: EXCELLENT

**H - STAINLESS HOSE**  
 MAX TEMP: 900°F(485°C) MOISTURE: EXCELLENT CHEMICAL: EXCELLENT ABRASION: EXCELLENT

**T - TEFLON**  
 MAX TEMP: 500°F(260°C) MOISTURE: EXCELLENT CHEMICAL: EXCELLENT ABRASION: GOOD

**S - FIBERGLASS STRANDED**  
 MAX TEMP: 900°F(485°C) MOISTURE: GOOD CHEMICAL: GOOD ABRASION: FAIR

### A40B - ORDER CODE

A40BX	-	A	-	B	-	C	-	X	-	X	-	X
TYPE	TIP LENGTH	STEM LENGTH	LEAD LENGTH	TERMINATION	LEADS	OPTIONS						
J - TYPE J	1/8 - 1/8" (3.2mm)	3 - 3" (76mm)	0 - NONE	0 - STRIPPED LEADS	F - FIBERGLASS STRANDED	U - UNGROUNDED						
K - TYPE K	3/16 - 3/16" (4.7mm)	4 - 4" (101mm)	6 - 6" (152mm)	1 - FORK TERMINALS	B - STAINLESS BRAID	N - 1/2"-20UNF GROUNDED						
T - TYPE T	1/4 - 1/4" (6.3mm)	6 - 6" (152mm)	24 - 24" (610mm)	2 - STANDARD MALE PLUG	H - STAINLESS HOSE	M18 - M18x1.5 THREAD						
RTD2 - PT100	X - CUSTOM	8 - 8" (203mm)	48 - 48" (1220mm)	3 - STANDARD FEMALE JACK	T - TEFLON	M14 - M14x1.5 THREAD						
RTD3 - PT100		X - CUSTOM	120 - 120" (1220mm)	4 - MINI MALE PLUG	S - FIBERGLASS SOLID							
			X - CUSTOM	5 - MINI FEMALE JACK								

**\*\*Standard Lead Time for Custom Parts 3-5 days MFG\*\***  
**If you need something that is not listed, contact us! We can probably make it**

## A40C - MELT BOLT T/C and RTD'S - CONICAL STYLE

### A40C - CONICAL STYLE

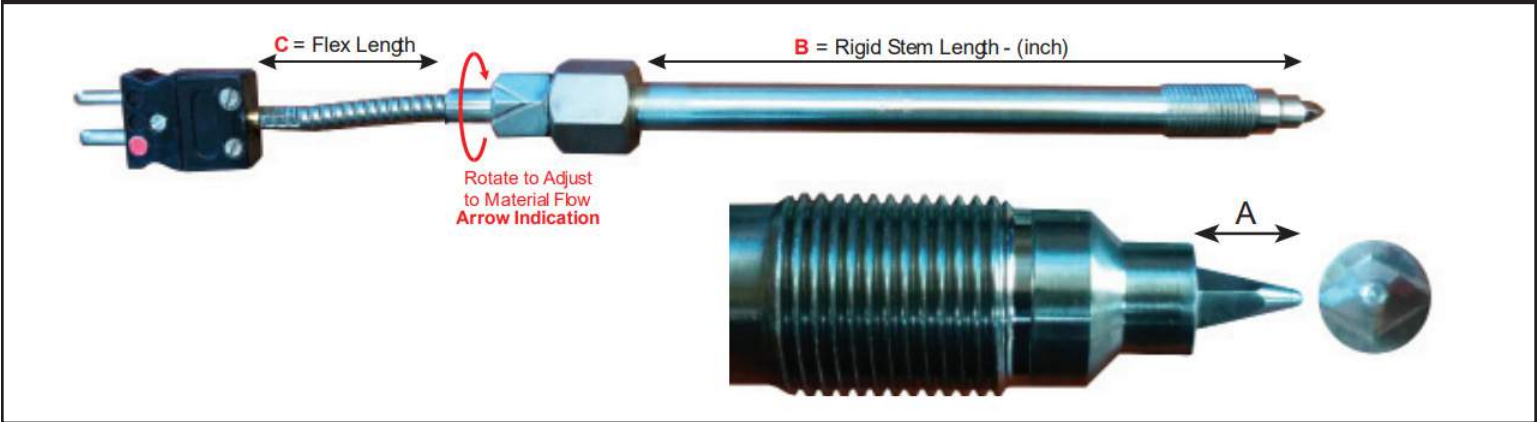

### STANDARD FEATURES

Max Pressure : 15,000psi (1000bar)  
 Max Temp : 900°F (450°C)  
 Body : 304 S/S  
 Tip Length : Flush to 1" (0-25mm)  
 Option : Ceramic insulated Tip

**Fits Standard Melt Pressure Transducer Hole**

### TERMINATIONS

#### 0 - STRIPPED LEADS

#### 1 - FORK TERMINALS

#### 2 - STANDARD MALE PLUG

#### 3 - STANDARD FEMALE

#### 4 - MINI MALE PLUG

#### 5 - MINI FEMALE JACK

### THREAD DIMENSIONS

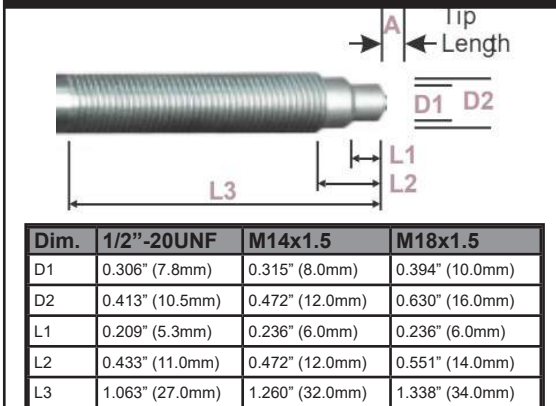

### A40C - ORDER CODE

**A40CX - A - B - C - X - X - X**

TYPE	TIP LENGTH	STEM LENGTH	LEAD LENGTH	TERMINATION	LEADS	OPTIONS
J - TYPE J	1/8 - 1/8" (3.2mm)	3 - 3" (76mm)	0 - NONE	0 - STRIPPED LEADS	F - FIBERGLASS STRANDED	U - UNGROUNDED
K - TYPE K	3/16 - 3/16" (4.7mm)	4 - 4" (101mm)	6 - 6" (152mm)	1 - FORK TERMINALS	B - STAINLESS BRAID	N - 1/2"-20UNF GROUNDED
T - TYPE T	1/4 - 1/4" (6.3mm)	6 - 6" (152mm)	24 - 24" (610mm)	2 - STANDARD MALE PLUG	H - STAINLESS HOSE	M18 - M18x1.5 THREAD
RTD2 - PT100	X - CUSTOM	8 - 8" (203mm)	48 - 48" (1220mm)	3 - STANDARD FEMALE JACK	T - TEFLON	M14 - M14x1.5 THREAD
RTD3 - PT100		X - CUSTOM	120 - 120" (1220mm)	4 - MINI MALE PLUG	S - FIBERGLASS SOLID	
			X - CUSTOM	5 - MINI FEMALE JACK		

**\*\*Standard Lead Time for Custom Parts 3-5 days MFG\*\***  
**If you need something that is not listed, contact us! We can probably make it**